

SPECIFICATIONS
PARTICLE COUNTER
KC-03B



3-20-41 Higashimotomachi, Kokubunji, Tokyo 185-8533, Japan

Outline

The light-scattering type airborne particle counter KC-03B is designed to measure the size and number of airborne particles using the light-scattering method, to determine the particle number concentration. This unit conforms to JIS B 9921⁻¹⁹⁹⁷ standard.

In a single measurement, the KC-03B can determine the particle count in five size ranges ($\geq 0.3 \mu\text{m}$, $\geq 0.5 \mu\text{m}$, $\geq 1 \mu\text{m}$, $\geq 2 \mu\text{m}$, and $\geq 5 \mu\text{m}$) in cleanrooms and particle controlled areas. The sample flow rate is 3 L/min.

The measurement result can be displayed as cumulative particle count for the measurement time, differential count between particle channels, or particle number concentration (particle count per sample volume). When the particle number concentration is displayed, selectable sample volume are 1 L, 28.3 L or 1000 L. Switching between different display settings during measurement is possible.

And the measurement can be repeated up to 99 times of preset time or volume and calculated average of results.

Printout of measurement results on an internal thermal printer is also possible.

A built-in serial interface allows for communication with a computer.

While the power is off, the measurement parameter settings is memorised automatically. Measurement to be continued with the same settings the next time power is on.

An alarm level can be set to sound a warning tone and control external equipment such as a fan when the particle count exceeds a preset threshold.

The KC-03B can output the measurement results converted into the analog signal with a range of 4 to 20 mA using an optional D/A converter interface, so it can be connected directly to a instrumentation system.

- * All company names and product names mentioned in this specifications are trademarks or registered trademarks of their respective owners.

Specifications

Sensor

Optical system	70° sideway light-scattering method
Light source	Laser-diode (wavelength 780 nm, rated output 40 mW)
Laser product classification	Class 1, IEC 60825-1 (2001) Internal particle detection mechanism uses Class 3B laser
Light collector	Aspherical lens (condensing half-angle 40 degrees)
Light detector	Si photodiode

Main unit

Air flow method	Purge-air keeps inside of sensor clean
Sample flow rate	3 L/min
Pump	Diaphragm pump
Flow control	Pressure sensing automatic control
Calibration	Polystyrene latex (PSL) particles in clean air (refractive index 1.6)
Minimum particle size	0.3 μm (for spherical particles with refractive index 1.6)
Particle size ranges	Five channels ($\geq 0.3 \mu\text{m}$, $\geq 0.5 \mu\text{m}$, $\geq 1 \mu\text{m}$, $\geq 2 \mu\text{m}$, and $\geq 5 \mu\text{m}$)
Maximum particle number concentration	30,000 particles/L (coincidence loss within 5%)
False count rate	Below 1 particle per 5 minutes
Measurement time	
Arbitrary:	00:00:10 to 02:00:00, and manual
Sample volume:	1 L (20 sec), 2.83 L (57 sec), 10 L (3 min 20 sec), 28.3 L (9 min 26 sec)

Measurement modes

Manual measurement Measurement controlled with START and STOP buttons

Automatic measurement

 Averaging measurement

 Repeated measurement up to 99 times of preset time or volume and averaging of results

 Periodic measurement

 Averaging measurement carried out at each specified time interval (00:00:10 to 24:00:00)

Count display modes Cumulative, differential, number concentration (unit: 1 L, 28.3 L, 1000 L)

Display	320 × 240 dot matrix type LCD, with backlight
Measurement screen	Measurement value (8 digits, 9999999.9 counts max., single-size display or all-size display), date, remaining measurement time, error message, setting and displaying of measurement parameters, etc.
System configuration screen	Date, time, communication parameters, auto print, flow rate and other system settings
LED indicators	
COUNT	Shows measurement status <ul style="list-style-type: none"> • Lit green when counting is in progress • Flashes green when sample air particle number concentration exceeds maximum rating • Off when measurement is stopped
FLOW	Shows sample air flow status <ul style="list-style-type: none"> • Lit green when sample air flow is within rated range • Flashes green when sample air flow is between -3 to -5% or +3 to +5% outside of rated range • Flashes red when sample air flow is more than ±5% outside of rated range • Off when pump is stopped
LASER	Shows light source (laser-diode) and particle detector status <ul style="list-style-type: none"> • Lit green when light source is operating normally • Lit red when temperature of light source is outside of rated range • Flashes red when light source output has fallen below rated level • Off when light source is off
Alarm function	Buzzer sounds and ALARM terminals are closed by relay when particle count in specified channel equals or exceeds specified alarm level.
Alarm level setting	1 to 9,999,999 particles (in 1-particle steps), and off Additional settings in remote mode: 100, 1000, 10000, 100000
Maximum load	30 V DC, 1 A

Controls

START button	Starts measurement
STOP button	Stops measurement
PARTICLE SIZE button	Switches particle sizes for display.
△, ▽ buttons	Control the cursor movement
FUNCTION buttons F1 to F4	Perform various functions as indicated on display
CONTRAST volume	Adjusts display contrast

Input/output connectors

ALARM	Terminals are closed by relay when the alarm occurs
EXT START/STOP (factory option)	For external measurement start/stop control

Internal interface

SERIAL	For communication with computer
--------	---------------------------------

Communication parameters

Electrical characteristics:

Conforming to JIS X 5101⁻¹⁹⁸²

(JIS X 5101⁻¹⁹⁸² corresponds to TIA/EIA-232.)

Transmission configuration:

Full-duplex, asynchronous

Baud rate: 4800 or 9600 bps

Data word length:

7 bits or 8 bits

Parity: Even, odd, or none

Stop bits: 2 or 1

Terminator: <CR LF> or <CR>

Connector type: 9-pin male D-sub connector

D/A converter interface (factory option)

Converts the particle count in a selected channel into 4 to 20 mA DC current

Particle count range

0 to 10, 0 to 100, 0 to 1000, 0 to 10000, 0 to 100000, 0 to 16, 0 to 256, 0 to 4096, 0 to 40960, 0 to 409600 (selectable)

Internal printer

Printing method	Thermal
Print width	48 mm

Inlet For sample air input

Outlet (factory option) For cleaned sample air output

Ambient conditions for operation

Shaded section in graph below (no condensation) without sudden temperature and humidity change

Using internal printer, however, 30% to 80% RH in graph below

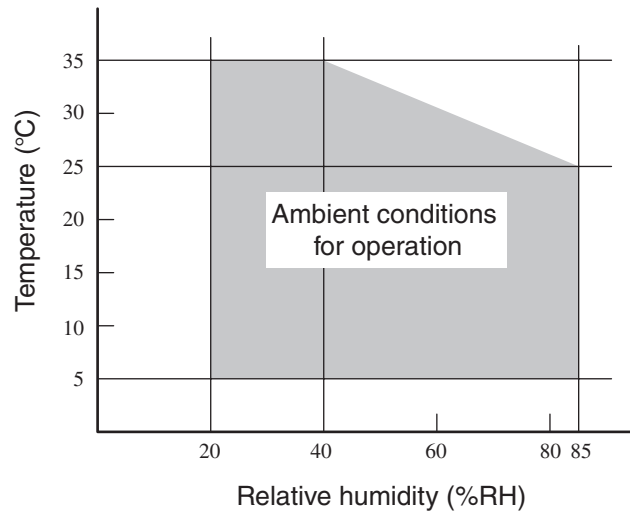

Ambient conditions for storage

-10°C to +50°C, 90% RH or less (no condensation)

Warm-up time 30 minutes

Power requirements 100 to 240 V AC, 50/60 Hz

Approx. 65 VA

Dimensions Approx. 158 (H) × 321 (W) × 316 (D) mm (max.)

Approx. 135 (H) × 300 (W) × 300 (D) mm (without protruding parts)

Weight Approx. 7.3 kg

Supplied accessories	Sampling pipe		1
	Sampling tube		1
	(Vinyl tube with 7 × 5 dia., 2 m)		
	Air filter		1
	Power cord		1
	(For use in Japan, 2.5 m)		
	Thermosensitive paper	TP-08	2
	Instruction manual		1
	Inspection certificate		1
Factory options	EXT START/STOP		
	Outlet		
	D/A converter interface		
Options	Interface cable	CC-61	
	(For connection to DTE with 25-pin female D-sub connector)		
	Interface cable	CC-61A	
	(For connection to DTE with 9-pin male D-sub connector)		
	Carrying case		
	Thermosensitive paper	TP-08 (6 rolls set)	
Lint-free thermosensitive paper	TP-10 (6 rolls set)		

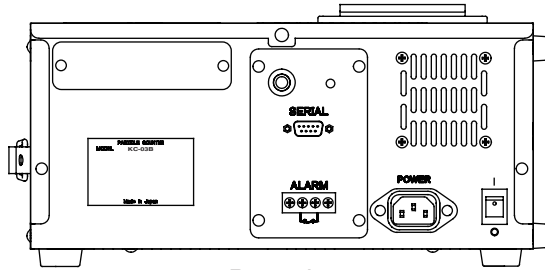

Rear view

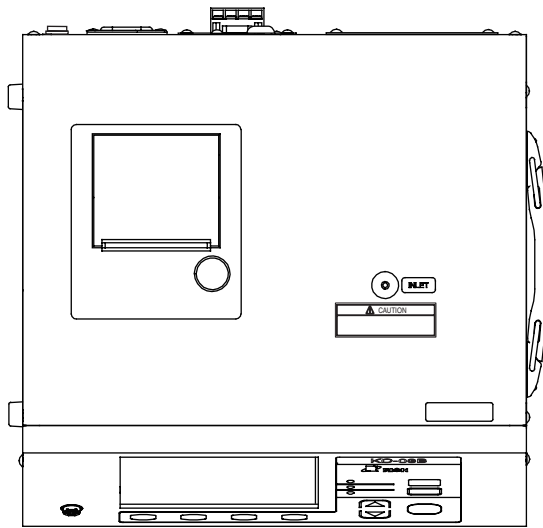

Top view

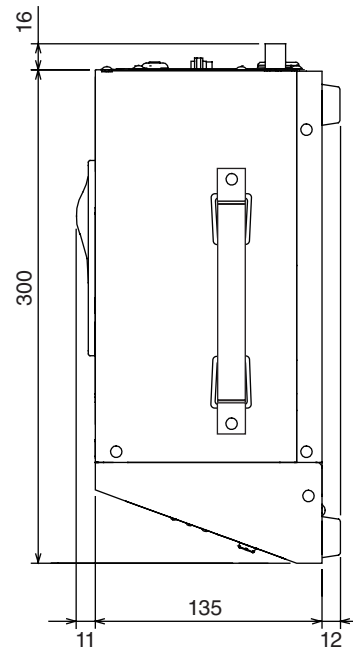

Right side view

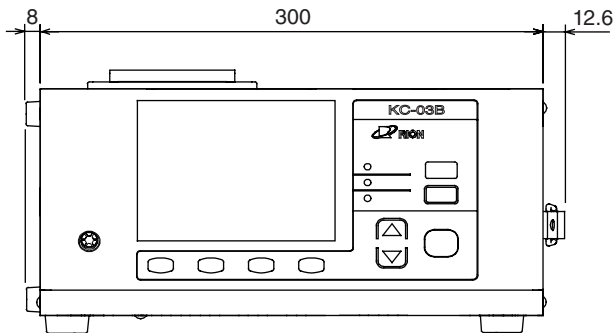

Front view

Unit: mm

Dimensional Drawings

Specifications subject to change without notice