

# **SPECIFICATIONS**

**CONTROLLER**

**KE-40B1**



3-20-41 Higashimotomachi, Kokubunji, Tokyo 185-8533, Japan

## Outline

This unit is a controller for use in combination with particle sensors such as the KS-42AF. It supplies power to the particle sensor, controls its operation, and displays measurement data, among other functions.

The unit can also be combined with the syringe sampler KZ-30W1 or KZ-30W2.

The display is a touch panel, so that buttons on the display can be selected and operated using the touch pen, or another suitable implement.

Printout of measurement results on an internal thermal printer is also possible.

An internal serial interface allows for communication with a computer.

Adding an optional CF card allows automatic saving measurement data in text format (as Tab-Separated Values (TSV)).

The unit can output the measurement results converted into an analog signal with a range of 4 mA to 20 mA using a factory option D/A converter interface, so it can be connected directly to an instrumentation system.

\* All company names and product names mentioned in this specifications are trademarks or registered trademarks of their respective owners.

## Specifications

### Display

Display 640 × 480 pixel color LCD (with backlight)

Display language English

### Display items

#### Measurement screen

This screen displays particle counts (up to 8 digits (one decimal place), one channel or up to ten channels on simultaneous display), date and time, remaining measurement time, error information, measurement parameter setting and display, etc.

#### System Configuration screen

Date, time, communication parameters, auto print and other system settings

### LED indicators

START Lights green to indicate measurement operation

Lights when measurement starts

Flashes when periodic measurement or preset-time measurement is paused (during measurement operation), and during purging

Otherwise, switched off

STOP	Lights green to indicate that measurement has stopped Lights when measurement or purging has stopped (when the START LED is not lit or flashing) Otherwise, switched off
PURGE	Lights green to indicate that the system is in syringe sampler Purge mode Lights when a syringe sampler is connected and Purge mode is selected, and during purge operation Flashes when the syringe sampler encounters an unexpected error when the system is in Purge mode Goes out when no syringe sampler is connected, or when the mode is not Purge mode
MEAS.	Lights green to indicate that the system is in syringe sampler measurement mode Lights when a syringe sampler is connected and Measurement mode is selected, and during Measurement operation Flashes when the syringe sampler encounters an unexpected error when the system is in Measurement mode Goes out when no syringe sampler is connected, or when the mode is not Measurement mode
COMBI.	Lights green to indicate that the system is in syringe sampler Combination mode Lights when a syringe sampler is connected and Combination mode is selected Flashes when the syringe sampler encounters an unexpected error when the system is in Combination mode Goes out when no syringe sampler is connected, or when the mode is not Combination mode

#### Controls

Touch panel	Resistance sensitive
Buttons	
START	Starts measurement, and instructs the syringe sampler to start operating
STOP	Stops measurement
MEAS.	Instructs the syringe sampler to enter Measurement mode
PURGE	Instructs the syringe sampler to enter Purge mode
COMBI.	Instructs the syringe sampler to enter Combination mode

Measurement time	10 seconds to 2 hours, and manual In Remote status, 1 or 10 minutes can be selected, in addition to the above
Measurement modes	
Manual measurement	Measurement controlled with START and STOP buttons
Automatic measurement	
Average measurement	Repeated measurement of preset time or volume, up to 99 times, with averaging of results
Periodic measurement	Repeated measurement can be performed automatically, specifying the time intervals (10 seconds to 24 hours)
Moving average measurement	During periodic measurement, moving average for 10, 60, or 100 measurements is calculated and results are output via printer, serial link, and D/A converter Processing results are not shown on the screen
Preset-time measurement	Starts/Stops measurement at the set time
Count display modes	Cumulative value, differential value, number concentration (units: /mL, /L)
Alarm	Buzzer sounds and ALARM terminals are closed by relay when particle count in the specified particle size range exceeds the specified alarm level When moving average measurement is carried out, buzzer sounds and ALARM terminals are closed by relay at end of measurement
Alarm level	1 to 9999999, or alarm is off 0.1 to 9999999.0, or alarm is off (at the time of moving average calculation) Additional settings in remote mode: Select from 10, 100, 1,000, 10,000, 100,000
Maximum load	30 V DC, 1 A
Terminal strip	M3 screw terminal strip (Connect spade terminals (Y-type) or wires of 1.25 mm <sup>2</sup> cross sectional area)

Clock	Auto calendar for year, month, day, hour, minute, second (adjusts for leap years until 2037) - Accuracy: $\pm 2$ minutes/month or better (at normal temperature)
Internal interfaces	
Serial interface	
Communications parameters	
Electrical characteristics	Compliant with JIS X 5101 <sup>-1982</sup> (JIS X 5101 corresponds to TIA/EIA-232)
Transmission configuration	Full-duplex, asynchronous
Baud rate	4,800 bps
Data word length	7 bits
Parity	Even
Stop bits	2 bits
Terminator	<CR> <LF>
Connector	9-pin male D-sub connector
D/A converter interface (factory option)	
Converts the particle count in a selected channel into 4 mA to 20 mA DC current	
Output range	Select one from 0 to 1, 0 to 10, 0 to 100, 0 to 1,000, 0 to 10,000, 0 to 100,000, 0 to 16, 0 to 256, 0 to 4,096, 0 to 40,960, 0 to 409,600
Load resistance	0 $\Omega$ to 500 $\Omega$ (including the resistance of the connection cable)
Output precision	$\pm 1\%$
Inputs/outputs	
SERIAL	Connect a control equipment compatible with the internal interface
SENSOR	Connect one connectable particle sensor
SAMPLER	Connect a syringe sampler (KZ-30W1/W2)
ALARM	Alarm output terminals
Internal printer	
Printout content	Measurement results, date and time, etc.
Printing method	Thermal printer, 48 mm print width
Printer paper	Thermal printer paper TP-08 or Lint-free thermal printer paper TP-10
Memory functions	Measurement data or others are automatically saved to CF cards in text (TSV) form

Power	100 V to 240 V AC, 50/60 Hz Approx. 130 VA
Environmental Requirements	
Operation Environments	
	Indoor Use Only
Altitude	Up to 2000 m
Supply Voltage Fluctuations	
	100 V to 240 V AC $\pm$ 10%
Overvoltage Category	II
Pollution Degree	2
Protection Class	I
Environmental conditions for operation	
	+5°C to +40°C, 85% RH max. (no condensation) Must be in the range 30% to 80% RH when using the printer. (no condensation)
Environmental conditions for storage	
	-10°C to +50°C, 90% RH max. (no freezing and no condensation)
Dimensions	Approx. 161 (H) $\times$ 245 (W) $\times$ 180 (D) mm (maximum dimensions) Approx. 140 (H) $\times$ 240 (W) $\times$ 146 (D) mm (without protruding parts)
Weight	Approx. 3 kg
Supplied Accessories	Power cord 1 Thermal printer paper TP-08 2 CF dummy card 1 Instruction manual 1 Inspection certificate 1
Factory option	D/A converter interface KE-40-S06
Options	Interface cable CC-61A (For connection to DTE with 9-pin male D-sub connector) Thermal printer paper TP-08 (6 rolls set) Lint-free thermal printer paper TP-10 (6 rolls set) Compact Flash card (formatted) MC-25LC1: 256 MB Compact Flash-PCMCIA adapter CFC-ADP03 RP monitor (monitoring software) K9461 RP monitor EVO (monitoring software) K0505

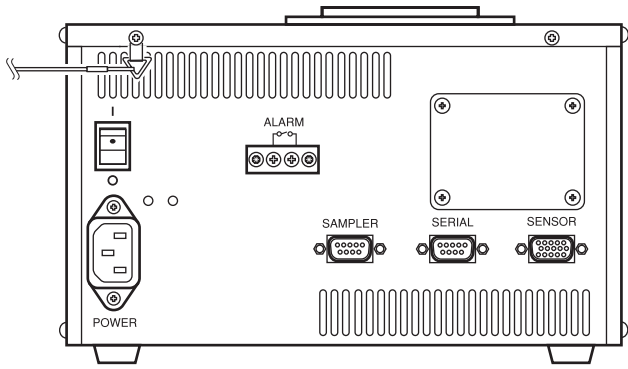

Rear view

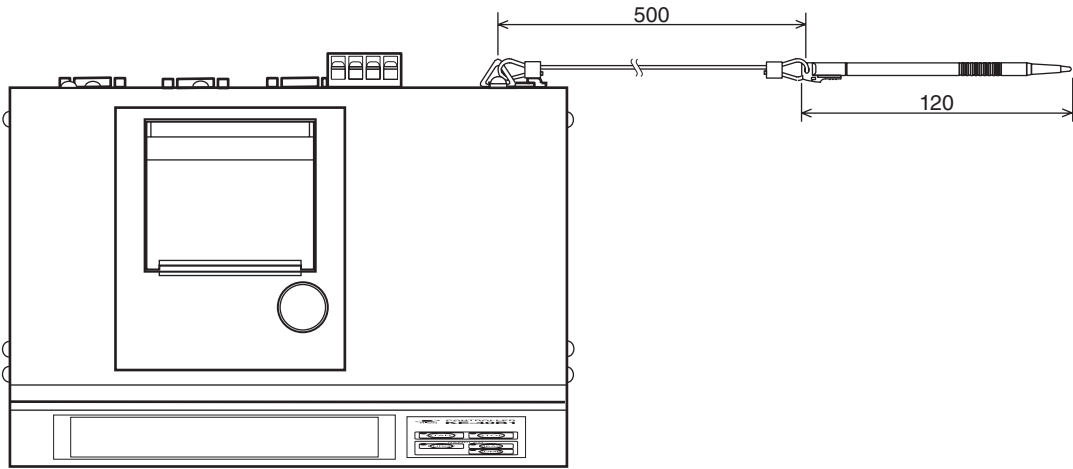

Top view

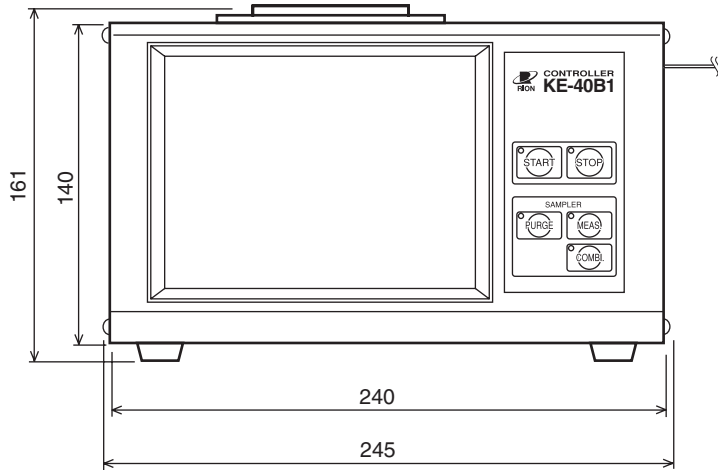

Front view

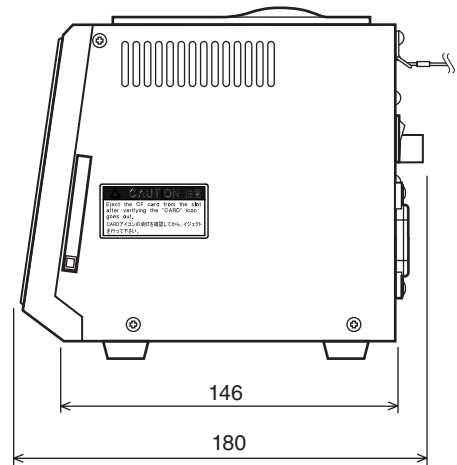

Right side view

Unit: mm

### Dimensional Drawings

Specifications subject to change without notice